



RHYNO 14.4V Compact  
Reciprocating Saw -  
OPERATOR'S MANUAL - USA





Catalog No: RWC-80

TO REDUCE THE RISK OF INJURY, USER MUST READ AND UNDERSTAND OPERATOR'S MANUAL.

## Definitions: Safety Guidelines

The definitions below describe the level of severity for each signal word. Please read the manual and pay attention to these symbols.

 **DANGER:** Indicates an imminently hazardous situation which, if not avoided, will result in death or serious injury.

 **WARNING:** Indicates a potentially hazardous situation which, if not avoided, could result in death or serious injury.

 **CAUTION:** Indicates a potentially hazardous situation which, if not avoided, may result in property damage.

**NOTICE:** Indicates a practice **not related to personal injury** which, if not avoided, may result in property damage.



## SYMBOLOLOGY

 **WARNING: USERS MUST READ ALL INSTRUCTIONS**

 **WARNING: To reduce the risk of injury, read the instruction manual before use. Read all warnings, safety instructions, and maintenance instructions before use and/or before performing any maintenance. Supervision is required when inexperienced or underage (<18 years) operators use this tool.**

RHYNO Windshield Cutter™ is a Trademark of EnTheos Design Solutions, LLC.

All rights reserved.

<b>V</b>	Volts
	Properly Recycled Batteries
<b>Hz</b>	Hertz
<b>AC</b>	Alternating Current
<b>DC</b>	Direct Current
<b>A</b>	Ampere
<b>AWG</b>	American Wire Gage
<b>LED</b>	Light Emitting Diode
<b>C</b>	Celcius
	WARNING – to reduce the risk of injury, user must read instruction manual
<b>F</b>	Fahrenheit

### RHYNO 14.4V Compact Reciprocating Saw

Tool Catalog Number	Tool Voltage (V)	No Load Speed	Stroke Length (inches)	Charger Catalog Number	AC Input Voltage (V)	AC Input Current (A)	DC Output Voltage (V)	Battery Catalog Number	Battery Capacity (Ah)	Battery Output Voltage (V)
RWC-80	14.4	0-3,400 Strokes	0.59	RWC-15	120	0.5	14.4	RWC-11	2.0	14.4
RWC-80	14.4	0-3,400 Strokes	0.59	RWC-15	120	0.5	14.4	RWC-12	5.0	14.4

## GENERAL POWER TOOL SAFETY WARNINGS



**WARNING: Read all safety warnings and all instructions.** Failure to follow the warnings and instructions may result in electric shock, fire and/or serious injury.



**Save all warnings and instructions for future reference.**

### 1) WORK AREA SAFETY

- a. **Keep work area clean and well lit.** Cluttered or dark areas invite accidents.
- b. **Do not operate power tools in explosive atmospheres, such as in the presence of flammable liquids, gases or dust.** Power tools create sparks which may ignite the dust or fumes.
- c. **Keep children and bystanders away while operating a power tool.** Distractions can cause you to lose control.

### 2) ELECTRICAL SAFETY

- a. **Power tool plugs must match the outlet. Never modify the plug in any way. Do not use any adapter plugs with earthed (grounded) power tools.** Unmodified plugs and matching outlets will reduce risk of electric shock.
- b. **Avoid body contact with earthed or grounded surfaces such as pipes, radiators, ranges and refrigerators.** There is an increased risk of electric shock if your body is earthed or grounded.
- c. **Do not expose power tools to rain or wet conditions.** Water entering a power tool will increase the risk of electric shock.
- d. **Do not abuse the cord. Never use the cord for carrying, pulling or unplugging the power tool. Keep cord away from heat, oil, sharp edges or moving parts.** Damaged or entangled cords increase the risk of electric shock.

- e. **When operating a power tool outdoors, use an extension cord suitable for outdoor use.** Use of a cord suitable for outdoor use reduces the risk of electric shock.
- f. **If operating the power tool in damp locations is unavoidable, use a Ground Fault Circuit Interrupter (GFCI) protected supply.** Use of a GFCI reduces the risk of electric shock.

### 3) PERSONAL SAFETY

- a. **Stay alert, watch what you are doing and use common sense when operating a power tool. Do not use a power tool while you are tired or under the influence of drugs, alcohol or medication.** A moment of inattention while operating power tools may result in serious personal injury.
- b. **Use personal protective equipment. Always wear eye protection.** Protective equipment such as safety glasses, dust mask, protective gloves or hearing protection used for appropriate conditions will reduce personal injuries.
- c. **Prevent unintentional starting. Ensure the switch is in the off-position before connecting to power source and/or battery pack, picking up or carrying the tool.** Carrying power tools with your finger on the switch or energizing the power tools that have the switch on invites accidents.
- d. **Remove any adjusting key or wrench before turning the power tool on.** A wrench or a key left attached to a

rotating part of the power tool may result in personal injury.

- e. **Do not overreach. Keep proper footing and balance at all times.** This enables better control of the power tool in unexpected situations.
- f. **Dress properly. Do not wear loose clothing or jewelry. Keep your hair, clothing and gloves away from moving parts.** Loose clothes, jewelry or long hair can be caught in moving parts.
- g. **If devices are provided for the connection of dust extraction and collection facilities, ensure these are connected and properly used.** Use of dust collection can reduce dust-related hazards.

#### 4) POWER TOOL USE AND CARE

- a. **Do not force the power tool. Use the correct power tool for your application.** The correct power tool will do the job better and safer at the rate for which it was designed.
- b. **Do not use the power tool if the switch does not turn on and off.** Any power tool that cannot be controlled with the switch is dangerous and must be repaired.
- c. **Disconnect the plug from the power source and/or the battery pack from the power tool before making any adjustments, changing accessories, or storing power tools.** Such preventive safety measures reduce the risk of starting the power tool accidentally.
- d. **Store idle power tools out of the reach of children and do not allow persons unfamiliar with the power tool or these instructions to operate the power tool.** Power tools are dangerous in the hands of untrained users.
- e. **Maintain power tools. Check for misalignment or binding of moving parts, breakage of parts and any other condition that may affect the power tool's operation. If damaged, have the**

**power tool repaired before use.** Many accidents are caused by poorly maintained power tools.

- f. **Keep cutting tools sharp and clean.** Properly maintained cutting tools with sharp cutting edges are less likely to bind and are easier to control.
- g. **Use the power tool, accessories and tool bits, etc. in accordance with these instructions, taking into account the working conditions and the work to be performed.** Use of the power tool for operations different from those intended could result in a hazardous situation.

#### 5) BATTERY TOOL USE AND CARE

- a. **Recharge only with the charger specified by the manufacturer.** A charger that is suitable for one type of battery pack may create a risk of fire when used with another battery pack.
- b. **Use power tools only with specifically designated battery packs.** Use of any other battery packs may create a risk of injury and fire.
- c. **When battery pack is not in use, keep it away from other metal objects like paper clips, coins, keys, nails, screws, or other small metal objects that can make a connection from one terminal to another.** Shorting the battery terminals together may cause burns or a fire.
- d. **Under abusive conditions, liquid may be ejected from the battery; avoid contact. If contact accidentally occurs, flush with water. If liquid contacts eyes, additionally seek medical help.** Liquid ejected from the battery may cause irritation or burns.

#### 6) SERVICE

- a. **Have your power tool serviced by a qualified repair person using only identical replacement parts.** This will ensure that the safety of the power tool is maintained.

## ADDITIONAL SAFETY RULES FOR SAWS

 **WARNING:** Tool use can generate and disburse particles and dust which project outward from the cutting blades that may impact the face, eyes, hands or other body parts. **ALWAYS** use ANSI Z87.1 or equivalent safety certified eye protection during operation. Everyday eyeglasses are NOT safety glasses.

 **WARNING:** Tool use can generate and disburse particles and dust which may cause serious and permanent respiratory or other injury. **ALWAYS** use NIOSH/OSHA safety certified respiratory protection during operation.

 **WARNING:** Exposed and cut edges along with pieces and particles can cut your skin. **ALWAYS** wear cut-resistant gloves constructed of leather, canvas or equivalent during operation.

 **WARNING:** Do not expose tool and accessories to water or wet conditions. Water entering a power tool will increase the risk of electric shock.

 **WARNING:** Depending on duration and conditions of use, this tool may generate noise which may contribute to hearing loss. **ALWAYS** use ANSI S12.6 or equivalent safety certified hearing protection during operation.

 **WARNING:** Tool use may generate particles, dust, or vapor which contains chemicals known to cause cancer, birth defects or other reproductive harm. Some examples of these chemicals include:

- Copper and plastic from wiring

Your risk from these exposures varies, depending on how often you do this type of work. To reduce your exposure to these chemicals, work in a well-ventilated area, and work with approved safety equipment, such as safety certified dust masks which are specially designed to filter out microscopic particles. Avoid prolonged contact with dust by allowing particles or dust to enter the mouth, eyes or lay on the skin which can promote absorption of harmful chemicals.

**Hold power tool by insulated gripping surfaces when performing an operation where the cutter blades may contact hidden wiring.** Cutting blades contacting “live” wires may make exposed metal parts of the power tools “live” and could give the operator an electric shock.

**Air vents on tool cover moving parts and should be avoided.** Loose clothes, jewelry or long hair can be caught in moving parts.

 **WARNING:** Do not use this tool if you are extremely tired, cannot maintain adequate attention or are under the influence of drugs, alcohol or medication. A moment of inattention while operating power tools may result in serious injury.

 **WARNING:** Do not use this tool in explosive atmospheres, such as in the presence of flammable liquids, gases or dust. Power tools create sparks which may ignite the gas or fumes.

**READ AND SAVE ALL INSTRUCTION FOR FUTURE REFERENCE.**

## SAFETY INSTRUCTIONS FOR BATTERY PACKS

**NOTICE:** The batteries included with your tool are not fully charged out of the carton. Before using the battery packs, read the safety instructions below. Then follow charging instructions outlined.

### 1) MAINTENANCE AND STORAGE

- a. **Do not charge or use battery in explosive atmospheres, such as in the presence of flammable liquids, gases or dust.** Inserting or removing the battery from the charger may ignite the dust or fumes.
- b. **NEVER force battery pack into charger. DO NOT modify battery pack in any way to fit into a non-compatible charger as battery pack may rupture causing serious personal injury.**
- c. Charge the battery packs only in charger provided with this tool.
- d. **DO NOT splash or immerse in water or other liquids.**
- e. **Do not store or use the tool and battery pack in locations where the temperature may reach or exceed 120°F (50°C) (such as outside sheds or metal buildings in summer).**

 **WARNING:** Fire Hazard. Never attempt to open the battery pack for any reason. If battery pack case is cracked or damaged, do not insert into charger. Do not crush, drop or damage battery pack. Do not use a battery pack or charger that has received a sharp blow, been dropped, run over or damaged in any way (i.e. pierced with a nail, hit with a hammer, stepped on).

 **WARNING:** Fire hazard. Do not store or carry battery so that metal objects can contact exposed battery terminals. For example, do not place battery in aprons, pockets, tool boxes, product kit boxes,

 **WARNING:** Burn hazard. Battery liquid may be flammable if exposed to spark or flame.

**Exposed battery terminals may cause fire if the terminals inadvertently come in contact with conductive materials such as keys, coins, hand tools and the like.** The US Department of Transportation Hazardous Material Regulations (HMR) actually prohibit transporting batteries in commerce or on airplanes (i.e. packed in suitcases and carry-on luggage) UNLESS they are properly protected from short circuits. So when transporting individual batteries, make sure that the battery terminals are protected and well insulated from materials that could contact them and cause a short circuit.

### 2) LITHIUM-ION BATTERIES

- a. **Do not incinerate the battery pack even if it is severely damaged or is completely worn out.** The battery pack can explode in a fire. Toxic fumes and materials are created when lithium ion battery packs are burned.
- b. **If battery contents come into contact with the skin, immediately wash the area with mild soap and water.** If battery liquid gets into the eye, rinse water over the open eye for 15 minutes or until irritation ceases. If medical attention is needed, the battery electrolyte is composed of a mixture of liquid organic carbonates and lithium salts.
- c. **Contents of opened battery cells may cause respiratory irritation.** Provide fresh air. If symptoms persist, seek medical attention.

## SAFETY INSTRUCTIONS FOR BATTERY CHARGERS



**WARNING:** Read and save these instructions for future reference. This manual contains important safety and operating instructions for battery chargers. Before using charger, read all instructions and cautionary markings on charger, battery pack, and product using the battery pack.

### 1) MAINTENANCE AND STORAGE

- a. **SAVE THESE INSTRUCTIONS** – This operator's manual contains important safety and operating instructions for RHYNO Compact Reciprocating Saw, 14.4V battery packs and 14.4V chargers.
- b. Before using the batteries and charger, read this operator's manual and all labels on the tool, battery pack and charger.
- c. Use RHYNO 14.4V Lithium-ion batteries only on 14.4V Lithium-ion tools and 14.4V Lithium-ion charger. Use with other tools and batteries may result in increased risk of fire, electric shock or personal injury.
- d. **Avoid dangerous environments. Do not charge battery pack in rain, snow, damp or wet locations.** Do not use battery pack or charger in the presence of explosive atmospheres (gaseous fumes, dust or flammable materials) because sparks may be generated when inserting or removing battery pack, possibly causing fire.
- e. **Charge in a well-ventilated area.** Do not block charger vents. Keep them clear to allow proper ventilation. Do not allow smoking or open flames near a charging battery pack. Vented gases may explode.
- f. **Maintain charger cord.** When unplugging charger, pull plug rather than cord to reduce the risk of damage to the electrical plug and cord.

Never carry charger by its cord. Keep cord from heat, oil and sharp edges. Make sure cord will not be stepped on, tripped over or subjected to damage or stress. Do not use charger with damaged cord or plug. Have a damaged cord replaced immediately with identical replacement parts (see "Maintenance").
- g. **Do not use an extension cord unless it is absolutely necessary.** Using the wrong, damaged or improperly wired extension cord could result in the risk of fire and electrical shock. If an extension cord must be used, plug the charger into a properly wired 16 gage or larger extension cord with pins that are the same number, size and shape as the pins on the charger. Make sure that the extension cord is in good electrical condition.
- h. **Charger RWC-15 is rated for 120V AC and 220V. Charger plugs may be Type A, C, G, or H.** Charger must be plugged into an appropriate receptacle with a matching rating.
- i. **Use only recommended attachments.** Use of an attachment not recommended or sold by the battery pack or battery charger manufacturer may result in an increased risk of fire, electric shock or personal injury.
- j. **Unplug charger when not in use.** Remove battery pack from unplugged chargers.

**Do not disassemble charger.** Incorrect reassembly may result in an increased risk of fire, electric shock, electrocution or exposure to battery chemicals. If

charger is damaged, take it to a certified RHYNO service facility.

- i. **Battery chemicals cause serious burns.** Never allow contact with skin, eyes
- m. **Do not operate charger if it has received a sharp blow, been dropped, or otherwise damaged in any way.** Contact the manufacturer for further instructions.
- n. **Do not short circuit.** A battery pack will short circuit if a metal object makes a connection between the positive and negative contacts on the battery pack. Do not place a battery pack near anything that may cause a short circuit, such as coins, keys or nails in your pocket. A short circuited battery pack may cause fire and personal injury.
- o. **Store your battery packs and charger** in a cool, dry place. Do not store battery pack where temperatures may exceed 120°F (50°C) such as in direct sunlight, a vehicle or metal building during the summer.

 **CAUTION:** To reduce the risk of injury, charge only RHYNO Windshield Cutter™ Lithium-ion batteries with only RHYNO Windshield Cutter™ chargers. Other types of chargers may cause personal injury or damage. Do not wire a battery pack to a power supply plug or car cigarette lighter. Batteries will be permanently disabled or damaged.

 **WARNING:** Burn hazard. To reduce the risk of injury, charge only RHYNO Windshield Cutter batteries. Other types of batteries may burst causing personal injury and damage.

 **WARNING:** Shock hazard. Do not allow any liquid to get inside charger. Electric shock may result.

 **WARNING:** Do not burn or incinerate a battery pack even if it is damaged, dead or completely discharged. When burned, toxic fumes and materials are created.

 **WARNING:** Shock hazard. ALWAYS unplug charger before cleaning or maintenance. Do not allow water to flow into AC plug. Use a Ground Fault Circuit Interrupter or GFCI to reduce shock hazards.

 **WARNING:** Burn hazard. NEVER allow battery chemicals to come into contact with eyes, skin or mouth. If a damaged battery pack leaks battery chemicals, use rubber or neoprene gloves to dispose of it. If skin is exposed to battery fluids, wash with soap and water and rinse with vinegar. If eyes are exposed to battery chemicals, immediately flush with water for 15 minutes and seek medical attention. Remove and dispose of contaminated clothing.

 **WARNING:** Use ONLY the battery charger and battery(s) provided with this tool set. Only this battery charger is matched to the lithium-ion battery for your power tool. Use charger indoors only.

**NOTICE:** The battery is supplied partially charged. To ensure full capacity of battery, completely charge the battery in the battery charger before using your power tool for the first time. The lithium-ion battery can be charged at any time without reducing its service life. Interrupting the charging procedure does not damage the battery.

Battery is protected against deep discharging by the “electric cell protection.” When the battery is empty, the tool will stop by means of a protective circuit. The tool will not operate until a charged battery has been re-installed.

 **WARNING:** DO NOT continue to press the On/Off switch after the machine has







been automatically switched off. The battery can be damaged.

## 2) WHEN TO CHARGE BATTERY PACK

- a. The fuel gage on the left side of the motor indicates the current battery capacity.



Indicator	Remaining battery capacity
 Full light on	(Over) 80%
 light on	50 ~ 80%
 light on	20 ~ 50%
 OFF	(Below) 20%

- b. Remove the battery pack from the tool for charging when needed. RHYNO Lithium-ion battery packs do not develop “memory” when charged after only a partial discharge. It is not necessary to run down the battery pack before placing it on the charger.

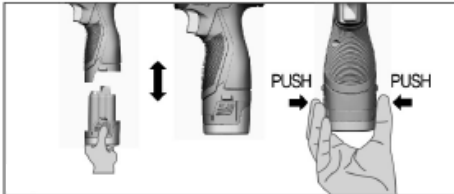

- c. You can “top off” each battery pack at any time or at any level of battery charge as needed.
- d. The only time that it is necessary to charge a battery pack is if it has reached the end of its charge. To signal the end of its charge, power to the tool will stop.

## 3) CHARGING A BATTERY PACK

- a. Align the battery pack with the bay and slide the battery pack into the charger as far as possible. The red LED will indicate charging is ongoing.
- b. A fully discharged battery pack with an internal temperature in the normal range will charge in about 15-20

minutes. Heavily cycled batteries may take longer to completely charged.

**NOTICE:** Hot or cold batteries will take longer to charge.





**NOTICE:** Inverters or generators rated to 100 watts or higher can be used to power charger.

## 4) CLEANING

Clean out dust and debris from charger vents and electrical contacts by blowing with compressed air. Use only mild soap and a damp cloth to clean the battery pack and charger, keeping away from the electrical contacts. Certain cleaning agents and solvents are harmful to plastics and other insulated parts. Some of these include gasoline, turpentine, lacquer thinner, paint thinner, chlorinated cleaning solvents, ammonia and household detergents containing ammonia. Never use flammable or combustible solvents around batteries, charger or tools.

## 5) REPAIRS

The charger has no serviceable parts.

Indicators		Meaning
Standby	 ▶ Green LED Flickering	▶ Battery charging is workable,
Charging	 ▶ Red LED on	▶ Battery is being charged.
Finish	 ▶ Green LED on	▶ Fully charged.
Battery High Temperature	 ▶ Red & Green LED on Red/Green	▶ Battery temperature has missed the normal range(0~45℃). Charge will automatically start when allowable temperature is reached.
Battery low voltage		▶ Pre-charging mode voltage of the battery is low. (When a constant voltage charging mode is switched to rise,)

## SAFETY INSTRUCTIONS FOR TOOL OPERATION



**WARNING: Read and save these instructions for future reference.** This manual contains important safety and operating instructions for battery chargers. Before using charger, read all instructions and cautionary markings on charger, battery pack, and product using the battery pack.

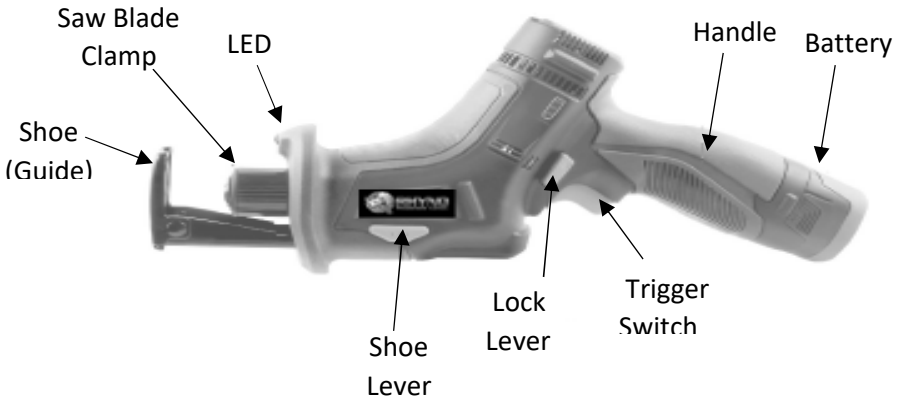

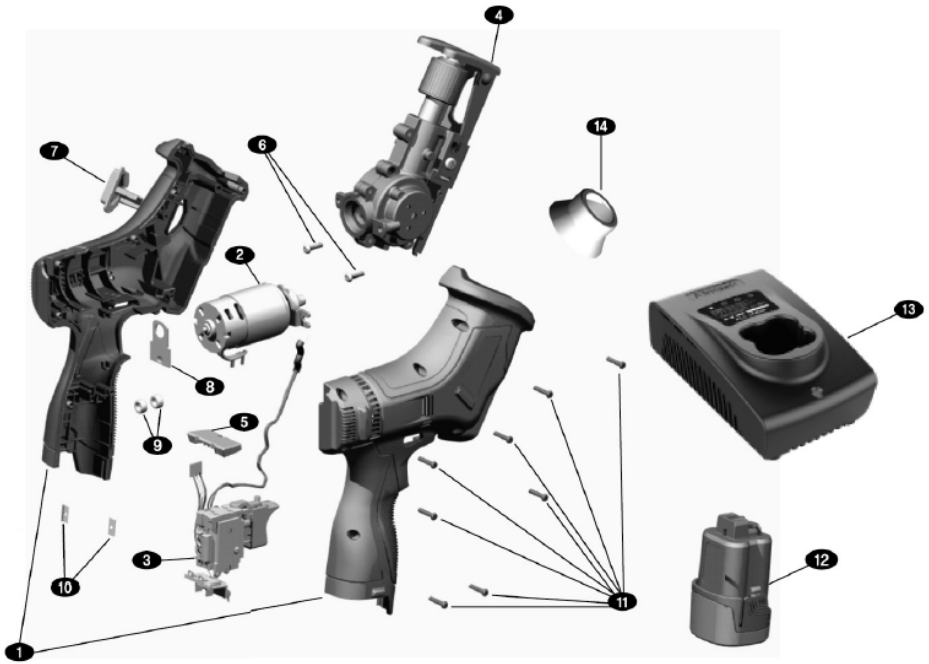

No.	Part Name	Qty.
1	Housing	1
2	Motor	1
3	Trigger Switch	1
4	Gear Box	1
5	Lock Lever	1
6	Star Screw	2
7	Shoe Lever	1

No.	Part Name	Qty.
8	Strap	1
9	Bead	2
10	Housing Clamp	2
11	Star Screw	8
12	Battery	2
13	Charger	1
14	Dust Protection Cap	1

### 1) INTENDED USE

- a. RHYNO Compact Reciprocating Saw is designed to cut a variety of materials like wood, steel and plastic. Material thickness will vary depending on the material type, hardness, blade type, etc. **DO NOT** use under wet conditions or in presence of flammable liquids or gases. This reciprocating saw is a professional power tool. **DO NOT** let children come into contact with the tool. Supervision is required when inexperienced operators use this tool.
- b. To activate the tool, squeeze the Trigger Switch. To stop the tool, release the trigger switch. Your tool is equipped

- with a brake. The saw blade will stop when the trigger switch is fully released.
- c. The variable-speed trigger switch allows you to start cutting at a slow speed. The further you squeeze the trigger, the faster the tool will operate. For maximum tool life, use variable speed during starts, stops and cornering.
- d. Your tool is equipped with a single work light (LED). The work light will be activated when the trigger switch is squeezed.
- e. Your tool is equipped with a Motor Control Lock. This Trigger Lock locks the trigger while in the center position and permits motor drive when to the left.

**⚠️ WARNING:** Work light is for providing light to the immediate work surface and is not intended to be used as a flashlight.

**⚠️ WARNING: CUT HAZARD. ALWAYS keep hands, fingers, hair, clothing and/or other body parts clear and away from between or near cutting blades. Severe injury will result.**

**⚠️ WARNING: CUT HAZARD. To reduce the risk of serious personal injury, disconnect the battery pack before making any adjustments, maintenance or removing/installing attachments or accessories. Severe injury will result.**

## 2) INSTALLING AND REMOVING SAW BLADES

- Remove battery pack before changing blades. Make sure the spindle and blade clamp areas are clean. Metal, wood and plastic chips/dust may prevent the blade clamp from locking securely.
- Depending on the job, the blade may be inserted with the teeth facing up or down. To install a blade, rotate the keyless blade clamp counterclockwise and insert a blade. Release the blade clamp to rotate automatically clockwise.
- Tug on blade to ensure secure blade locking in the chuck.
- To remove the saw blade, rotate the blade clamp counter clockwise and pull the blade from the clamp. Be careful when handling hot blades.
- Broken blades can be removed by removing the battery pack, point tool downward and shake tool up and down. DO NOT turn tool on while your fingers are holding the blade clamp open. If unsuccessful, most blades break with a corner extending outward from the clamp which can be grasped with the fingers or pliers. Otherwise, if the blade is below the

clamp, use a thin blade with small teeth to hook the blade that is jammed in the clamp and remove the broken blade.

**⚠️ WARNING:** To reduce the risk of injury, be sure the blade always extends beyond the shoe and workpiece throughout the stroke. Blades may shatter if they impact the workpiece or shoe.

## 3) INSTALLING DUST PROTECTION CAP

- Anti-dust cap is provided to deflect dust and chips away from motor.
- Remove battery pack and extend shoe fully. Place dust cover over blade clamp.

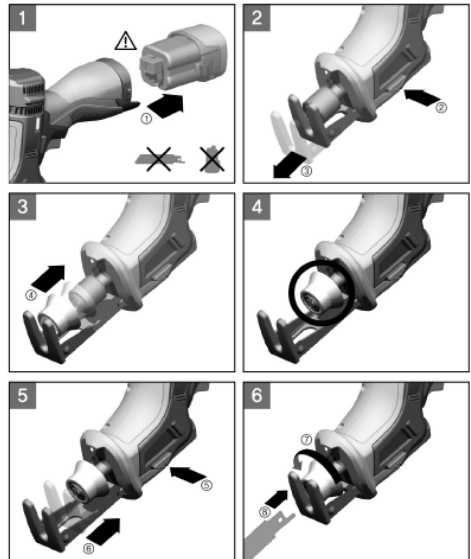

**⚠️ WARNING: ALWAYS** remove battery pack before cleaning or maintenance.

## 4) CLEANING AND MAINTENANCE

- Keep tool clean and inspect it regularly.
- Only use a dry soft cloth for wiping tool. DO NOT use a damp cloth, thinner, benzene or other volatile solvent for cleaning.
- Lubricate the piston periodically with suitable lubrication oil to maintain a normal tool life.

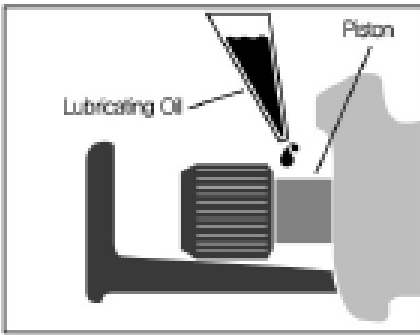

## 5) STORAGE RECOMMENDATIONS

- a. The best storage place is one that is cool and dry away from direct sunlight and excess heat or cold.
- b. Long storage will not harm the battery pack or charger. Under proper conditions, battery pack and charger can be stored for at least 1 year or more.

## 6) REPLACEMENT PARTS

The battery pack for RHYNO Compact Reciprocating Saw is RWC-11 (2.0Ah Li-Ion Battery) or RWC-12 (5.0Ah Li-Ion Battery). The battery charger for RHYNO Compact Reciprocating Saw is RWC-15. Battery Charger plugs vary (Type A, C, G and H). Type A is for Japan, Type C is CE-Europe, Type G is UK, Type I is China. All these components are replaceable parts. Contact info:

### **We Cut The Glass, LLC.**

4960 William Flynn Highway  
Suite 6, #350  
Allison Park, PA 15101  
Toll Free: 844-25RHYNO  
Fax 484.991.1952  
Email: info@RHYNO.com

NOTES:

NOTES:

## LIMITED WARRANTY

Every *RHYNO* tool including battery and battery charger, is warranted to the original purchaser only to be free from defects in material and workmanship. Subject to certain exceptions, We Cut The Glass, LLC will repair or replace any part which after examination, is determined by We Cut The Glass, LLC to be defective in material or workmanship for a period of two (2) years after the date of purchase unless otherwise noted. Return of the tool to a *RHYNO Windshield Cutter™* factory service center location, freight prepaid and insured, is required. A copy of the proof of purchase should be included with the return product. This warranty does not apply to damage that personnel, misuse, alterations abuse, normal wear and tear, lack of maintenance or accidents. The manufacturing date of the product will be used to determine the warranty period if no proof of purchase is provided at the time of warranty service is requested.

ACCEPTANCE OF THE EXCLUSIVE REPAIR AND REPLACEMENT REMEDIES DESCRIBED HEREIN IS A CONDITION OF THE CONTRACT FOR THE PURCHASE OF EVERY RHYNO Windshield Cutter™. IF YOU DO NOT AGREE TO THIS CONDITION, YOU SHOULD NOT PURCHASE THE PRODUCT. IN NO EVENT SHALL WE CUT THE GLASS, LLC BE LIABLE FOR ANY INCIDENTAL, SPECIAL, CONSEQUENTIAL OR PUNITIVE DAMAGES, OR FOR ANY COSTS, ATTORNEY FEES, EXPENSES, LOSSES OR DELAYS ALLEGED TO BE AS A CONSEQUENCE OF ANY DAMAGE TO, FAILURE OF, OR DEFECT IN ANY PRODUCT INCLUDING, BUT NOT LIMITED TO, ANY CLAIMS FOR LOSS OF PROFITS. SOME STATES DO NOT ALLOW THE EXCLUSION OR LIMITATION OF INCIDENTAL OR CONSEQUENTIAL DAMAGES, SO THE ABOVE LIMITATION OR EXCLUSION MAY NOT APPLY TO YOU. THIS WARRANTY IS EXCLUSIVE AND IN LIEU OF ALL OTHER EXPRESS WARRANTIES, WRITTEN OR ORAL. TO THE EXTENT PERMITTED BY LAW, WE CUT THE GLASS, LLC DISCLAIMS ANY IMPLIED WARRANTIES, INCLUDING WITHOUT LIMITATION ANY IMPLIED WARRANTY OF MERCHANTABILITY OR FITNESS FOR A PARTICULAR USE OR PURPOSE; TO THE EXTENT SUCH DISCLAIMER IS NOT PERMITTED BY LAW, SUCH IMPLIED WARRANTIES ARE LIMITED TO THE DURATION OF THE APPLICABLE EXPRESS WARRANTY AS LASTS, SO THE ABOVE LIMITATION MAY NOT APPLY TO YOU. THIS WARRANTY GIVES YOU SPECIFIC LEGAL RIGHTS, AND YOU MAY ALSO HAVE OTHER RIGHTS WHICH VARY FROM STATE TO STATE. This warranty applies to product sold in the USA and Canada Only.

No warrant is provided for any product which has been modified in any way. Check with your international supplier to determine if international warranties apply. Our sole liability is to repair or replace covered parts and components. This is the exclusive remedy for consequential damages.

Obtain from us while this warranty is valid and in-effect, prior authorization for return or repair of covered parts and components is required.